

# iBird® Pro

**NEW**



**iBird® Pro – the latest tool in the Pro series can be networked with a smartphone, tablet or PC via an app!**



## Advantages at a glance

**NEW**



### Technical facts

- WiFi 2.4/5.0 GHz and Bluetooth (LE) wireless connection
- Tilt sensor can be connected via the app; during use, the tool is only enabled for the next riveting process once the tilting motion for ejecting the mandrel body has been performed
- Andon ring: Signal ring for visualising the riveting process, the colours can be set individually via the app

### Premium software: optional setting process assistant\*

- Setting process evaluation with fault detection, notification in app and via Andon ring (signal ring lights up based on the setting process evaluation and colour setting)
- Teaching mode for teaching in rivet configurations
- Creation of job lists to process various rivet configurations

**Part no. 157 0451**

### Industry 4.0 with the iBird® Pro

Known as Industry 4.0, M2M or the Internet of Things, these concepts refer to intelligent and digitally networked systems in the production industry. The aim is to ensure that production is as self-organised as possible.

GESIPA® has developed the iBird® Pro with this in mind. The iBird® Pro is a networked battery-powered setting tool that can be connected to smartphones, tablets or a customer's IT infrastructure using WiFi or Bluetooth via a free GESIPA® app. This networking provides a number of additional benefits such as the monitoring of riveting processes, processing safety, status and service indicators, as well as quick and simple access to operating, maintenance and repair instructions – ultimately resulting in optimisation of the value chain.

### The GESIPA® app

Using a QR code, the iBird® Pro can be connected to the GESIPA® app with ease. The app is available for smartphones, tablets and PCs (Android and iOS). The iBird® Pro can be connected to three devices at the same time.

### The Andon ring

The iBird® Pro incorporates a signal ring for visualising riveting processes. The colours can be set individually via the app.

**Simple connection of the iBird® Pro with the GESIPA® app via QR code**

**For smartphone, tablet, PC (Android and iOS)**

**Premium software: setting process assistant**

**Connection with three smartphones, tablets or PCs at the same time (e.g. operator, foreman, process control centre)**



### What the iBird® Pro app offers:

- Various counters: Total, day, setting counter, countdown, OK\*, NOK\*.
- Fill level indicator, service indicator (spent mandrel container, cleaning or oiling jaws, full service)
- Optional setting process assistant\*
- Monitoring of battery charge level, battery temperature and temperature of the tool control
- Maintenance instructions, maintenance history
- Error message, error history, acknowledgement history
- Tips and tricks
- Operating instructions

\*Once paid premium software has been activated



# iBird® Pro

**NEW**

**iBird® Pro – the optional setting process assistant from GESIPA® provides assistance when evaluating riveting processes**

## iBird® Pro

With slide-on, rechargeable 18.0 V/2.1 Ah battery pack and charger in plastic carrying case

**Part no. 156 7800**

## iBird® Pro

With two slide-on, rechargeable 18.0 V/2.1 Ah battery packs and charger\* in plastic carrying

**Part no. 156 7801**

\* Supplied with Euro plug as standard (other versions on request)

## Powerful and fast

The iBird® Pro enhances the new Pro series. With a setting force of 15,000 N and the well-proven brushless motor, the iBird® Pro is powerful and fast when setting blind rivets up to Ø 6.4 mm in any material. The optional Autoreverse function additionally shortens the pulling process, ensuring the iBird® Pro is immediately ready for operation. The stroke has been substantially increased to 25 mm for the purpose of setting particularly long rivets.



## Even faster, virtually no wear

Since no wear-prone brushes are used, the motor of the iBird® Pro has an extremely long service life, is virtually non-wearing and reliably guarantees the fastest setting frequencies.

## Well-proven and ergonomically designed

The iBird® Pro is equipped with the low-wear jaws system and features the same ergonomic design as the TAURUS® series, already proven a thousand times over.

## The variable tool

Blind rivets from Ø 4.8 mm steel, up to Ø 6.4 mm all materials, up to Ø 8 mm aluminium, except G-Bulb Ø 6.4 mm. BULB-TITE® blind rivets up to Ø 7.7 mm all materials. MEGA GRIP® blind rivets up to Ø 6.4 mm all materials.

**Make sure the correct jaw pusher is used as specified in the operating instructions!**

**Technical data and accessories are the same as for the PowerBird® Pro and can be found on page 97.**

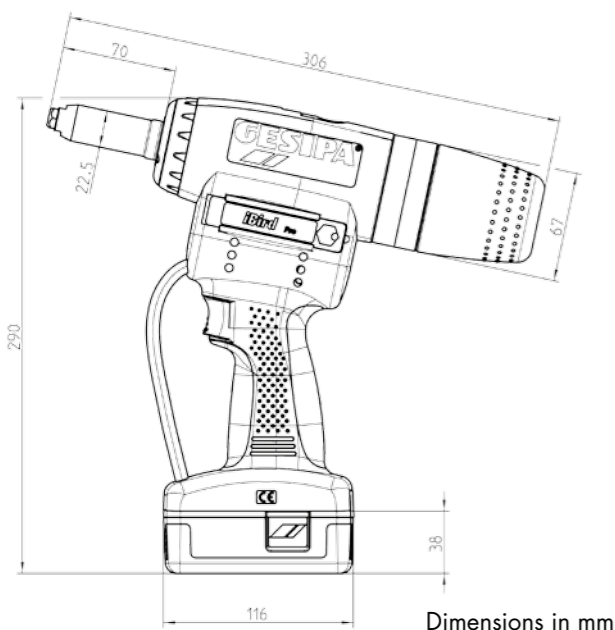

Dimensions in mm

## The GESIPA® iBird® Pro app – simple connection and all information you need at a glance!

### Connection

The iBird® Pro is extremely simple to connect thanks to the QR code located on your tool. Simply scan the QR code with the GESIPA® app (included in scope of delivery) and the iBird® Pro will automatically connect to your device.

It couldn't be simpler – no cabling and no modifications to menu settings in the device are needed.

### Tool control

Now you have all the information you need at a glance! The GESIPA® iBird® Pro app displays the process status, counter reading and special events. How much longer will the battery last? When do I need to empty the spent mandrel container? How many rivets have been set per day? You can answer all these questions straight away by taking a look at the app.

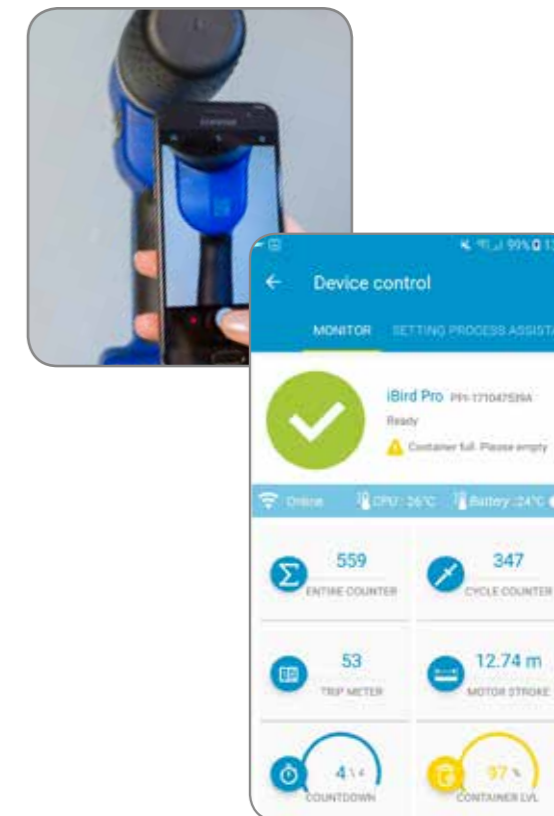

### Setting process assistant

The optional setting process assistant from GESIPA® helps operators to adjust the setting process and evaluate riveting processes.

If a fault is detected, a message is issued in the app and the Andon ring lights up in colour.

Teaching mode – simple learning of rivet configurations and setting of the tolerance window by means of the virtual control dial.

### Operation and maintenance

Tips and tricks for handling the iBird® Pro or quick access to the operating instructions are available directly, with ease and at any location with the iBird® Pro app.

You have access to illustrated maintenance instructions at any time, and even error messages are displayed to you in the app.

